

# CV-4 VERTICAL SLICER

**MAINALI**  
LONG LIFE TECHNOLOGY

**DESIGNED FOR  
CUTTING BONELESS  
PRODUCTS**

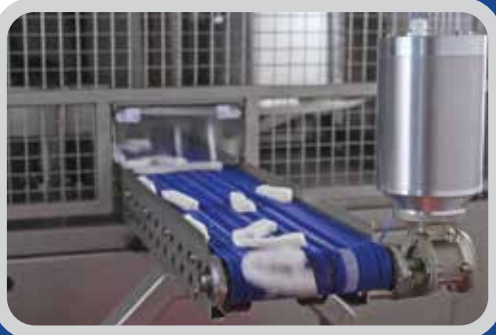

*\* Non-binding image, slight variations may occur.*

Designed for cutting boneless products. The product temperature can range from -10 to 0°C depending on the product morphology and desired thickness.

The cutting disc is positioned horizontally and has stainless steel protection.

The product is placed vertically on a rotating support with 4 customizable loaders, depending on the type of product to be cut.

The cutting disc and the rotating loading support are driven by independent geared motors with variable speeds.

The cutting thickness is electrically adjustable, and the position of the disc can be fixed allowing precise portions to be obtained.

During the cutting operation, the pneumatic cylinders push the product constantly into the loader to achieve **maximum homogeneity in weight, shape and thickness**.

The cut product is evacuated by means of a conveyor belt with variable speed.

Integrated electrical panel with variable speed drives for the cutting disc, the product support and the conveyor belt.

The equipment protections are made of stainless-steel mesh with doors for product loading and side doors for easy access.

The CV-4 vertical slicer is manufactured of stainless steel and food-grade plastic materials.

## TECHNICAL CHARACTERISTICS

### CV-4

ELECTRICAL POWER 2,5kW

AIR CONSUMPTION 2,5L/cycle

WEIGHT 700Kg

VOLTAGE 380-490V III+PE or 220-240V III+PE

OVERALL DIMENSIONS: 840mm L / 1200mm W / 2282mm H

SAMPLE MOULD SIZE: 210mm L / 90mm W / 800mm H

Constant pressure pusher cylinders

Electrical disc height adjustment

Safety protections

Exit conveyor with variable speed

Cutting disc with variable speed and electric brake

Carousel with 4 compartments, variable speed

Materials stainless steel and food-grade plastics

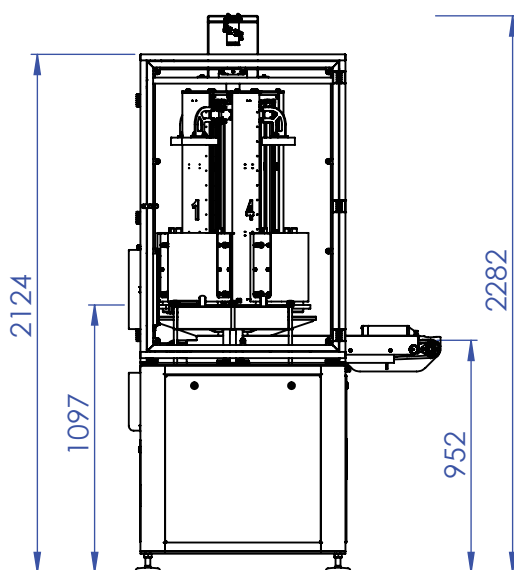
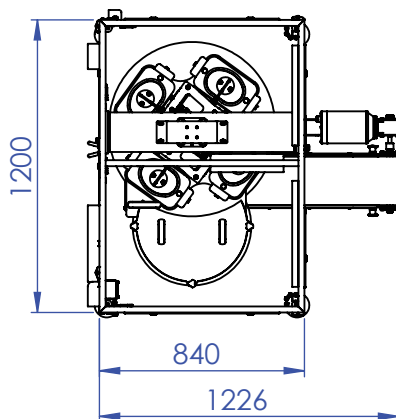

### OPTIONAL

SECURITY BARRIERS IN THE LOADING AREA

CUSTOMIZED MOLDS

PLC WITH RECIPES

INTEGRATED DISC SHARPENER

CUSTOMIZED LOAD-ROTATING SUPPORT

TAILORED PRODUCT EXIT CONVEYOR BELT

