

# SPLITTER SAW LONGITUDINAL & TRANSVERSAL CUT

**MAINALI**  
LONG LIFE TECHNOLOGY

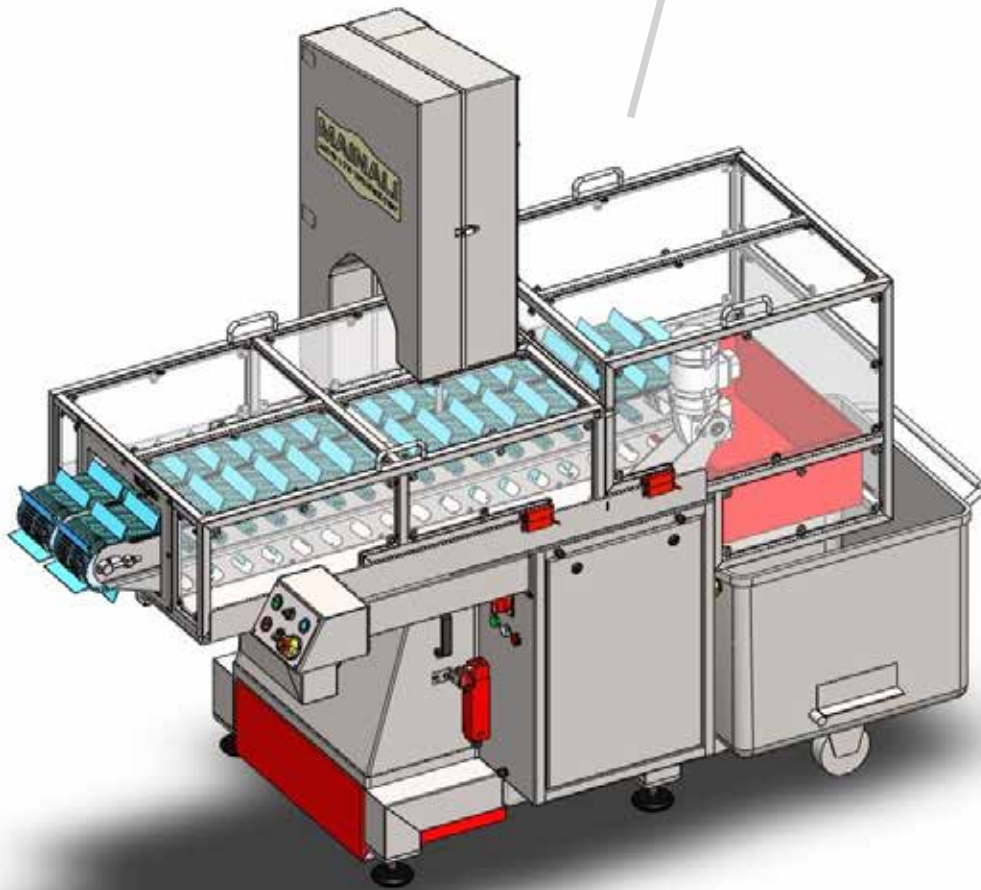

*\* Non-binding image, slight variations may occur.*

The SPLITTER SAW with splitting conveyor has a special design with one saw that provides longitudinal & transversal cuts.

It has been developed to make the cuts safely and quickly. It is a continuous cycle machine, compact and easy to use.

The machine consists of lateral traction belts or a tunnel, depending on the type of product to be cut.

The SPLITTER SAW stands out for its safety and versatility, it can be customized according to the customer's needs.

The operator, who is not specialized, has to introduce the product and it comes out on the other side cut into two pieces, avoiding the risk of labor accidents.

The SPLITTER SAW is capable of absorbing as many parts as an operator is able to feed into it, so the machine increases production exponentially and eliminates the risk of accidents at work.

**ELECTRICAL POWER 6kW**

**WEIGHT 650Kg**

**VOLTAGE 380-480V III+PE o 220-240V III+PE**

**OVERALL DIMENSIONS 1239mm L / 1916mm W / 2048mm H**

**Damped adjustment systems**

**Quick opening system**

**Pneumatic belt release system**

## TECHNICAL CHARACTERISTICS

